

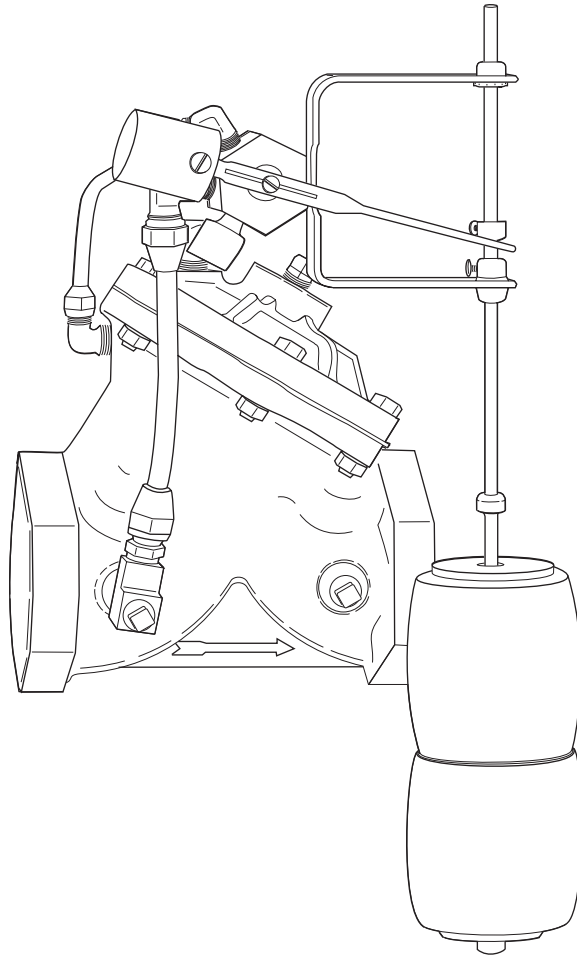

AQMATIC FLOAT OPERATED BRINE VALVE

INSTALLATION INSTRUCTIONS



DESCRIPTION

The AquaMatic Brine Control Valve is a pilot-controlled, hydraulically-operated Y-pattern diaphragm valve. It is controlled by pressure and vacuum which determines the upper and lower brine levels in the tank.

The valve will allow a predetermined amount of brine to be withdrawn and automatically refill with fresh water through a common line. Refilling is achieved while the softener is in fast rinse and service.

FEATURES

- Positive opening and closing of valve by combining vacuum and pressure.
- Pilot uses fresh water and vacuum for control pressures.
- Air and drip-tight closure after brining and also refilling.
- Completely automatic in the opening and closing operation of the brine and refill cycles.

OPERATION

With the softener in service position and brine tank at the predetermined upper level, line pressure is directed to the upper chamber of the diaphragm valve. This closes the valve. The lower chamber of the valve is vented to atmosphere through the pilot control.

With the softener in brine position, the vacuum created by the action of the ejector is transferred through the pilot control to the upper chamber of the diaphragm valve. The valve opens to allow brine to be withdrawn from the brine tank.

When the predetermined amount of brine has been withdrawn, the float contacts the lower float stop. The weight of the float will cause the lever arm to rotate to the down position. The vacuum is transferred to the lower chamber. This closes the valve and stops the flow of brine. The valve remains closed until the fast rinse cycle occurs.

With the softener in the fast rinse position, line pressure replaces the vacuum in the lower chamber. This will force the valve to the open position and allow the fresh water to refill the brine tank. At the predetermined upper level the float contacts the upper float stop. The lever arm rotates to the up position and pressure is directed to the upper chamber of the diaphragm valve. This will close the valve (drip-tight) until the next brine cycle.

SPECIFICATIONS

Size:	3/4" through 1.5" NPT or BSP
Pressure:	125 psi maximum recommended
Vacuum:	2 - 28 inHg
Temperature:	32 to 140»F (0 to 60»C)
Fluid:	Water and salt brine
Materials:	
	Body and cover - cast iron
	Valve trim - brass and stainless steel
	Seals - Buna-N
Diaphragm:	Buna-N on nylon
Pilot Control:	Brass
	Stainless steel
	Neoprene gasket
	Buna-N O-ring
	PTFE template
Float Rod:	Brass
Float:	Close-celled Spongex

CALIFORNIA PROPOSITION 65 WARNING

⚠ WARNING: This product contains chemicals known to the State of California to cause cancer or birth defects or other reproductive harm.

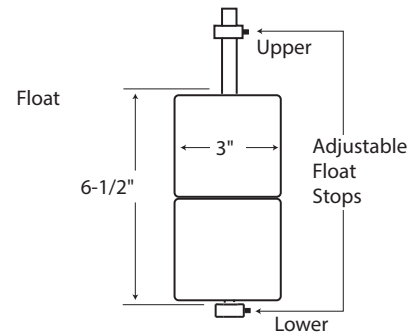
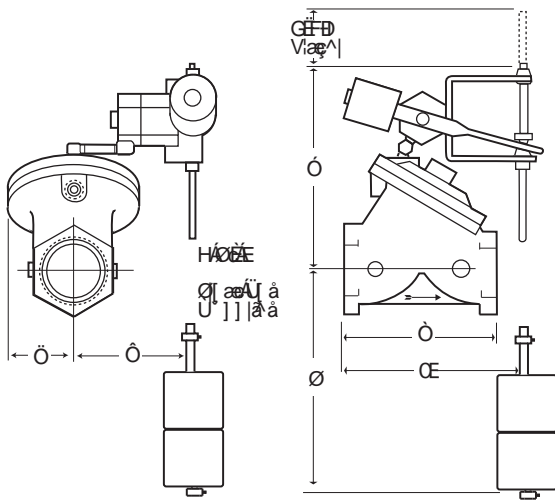
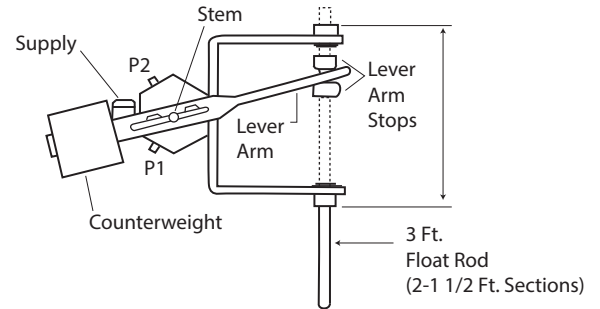
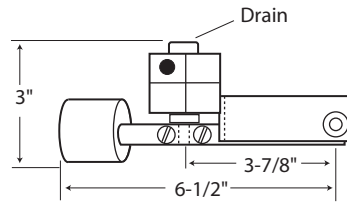
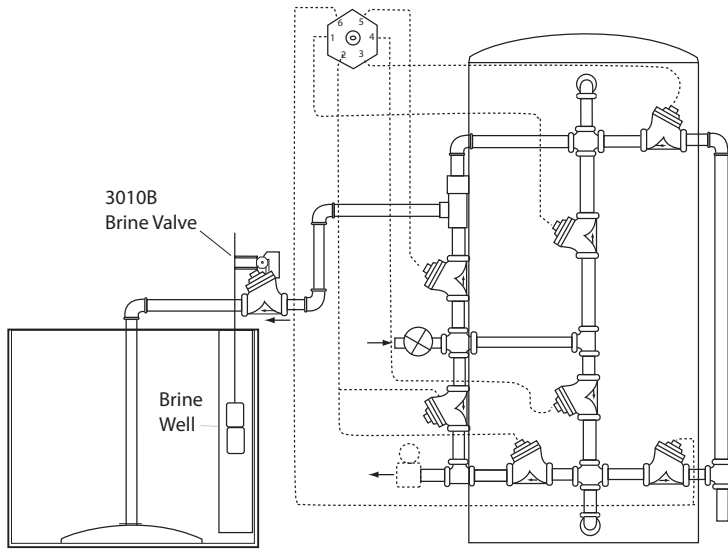

GlnY	8 ja "	5	6	7	8	9	: †
3/4" to 1"	in	7.31	6.50	1.50	2.12	3.68	29
	mm	186	165	38	54	93	735
1-1/4" to 1-1/2"	in	6.31	7.81	3.31	1.75	4.75	28
	mm	160	198	84	44	120	711

INSTALLATION

- Before installation, the pipe lines should be flushed thoroughly to remove all chips, scale, and other foreign matter
- Valve should be installed with refill flow in the direction as shown by the arrow on the body of the valve.
- The float rod should be installed as shown above.
- The counterweight should be adjusted to balance the weight of the float rod.
- Float is now installed on the float rod. The spacing between the float stops determines the travel or range of the float. This travel controls the amount of brine to be transferred to the softener tank.
- Calculate the amount of brine required for a regeneration cycle. Convert gallons of brine to number of inches of draw down in the brine tank. Adjust distance between "Adjustable float stops" on float rod to achieve proper brine draw down.
- Once the correct draw down has been established, the upper liquid level in the brine tank can be controlled by adjusting "lever arm stops". This action does not affect the brine draw down controlled by the float.



16605 West Victor Rd. New Berlin, WI 53151
P: 262-326-0100 | www.aq-matic.com | techsupport@aq-matic.com

© 2016 AQ Matic Valve and Controls Company, Inc. All rights reserved.

All AQ Matic trademarks and logos are owned by AQ Matic or its affiliates. All other registered and unregistered trademarks and logos are the property of their respective owners. Because we are continuously improving our products and services, AQ Matic reserves the right to change specifications without prior notice. AQ Matic is an equal opportunity employer.

1204627 REV E FEB2024